

PX 1350

PX 135

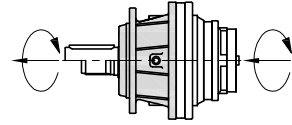

i	T ₂ (Nm)						n _{1max} (min ⁻¹)	T _{2max} (Nm)	P _t (kW)	
	n ₂ x h									
	10000	25000	50000	100000	500000	1000000				
1351	4.18	177575	144655	123750	105060	66975	54585	350	293000	75
	4.89	151515	139050	117450	99900	61620	50050	350	250000	75
	6.00	120000	103270	92180	91270	61360	49840	350	198000	75
1352	17.4	177575	144655	123750	105060	66975	54585	1500	293000	55
	20.4	177575	144655	123750	105060	66975	54585	1500	293000	55
	23.9	151515	139050	117450	99900	61620	50050	1500	250000	55
	25.1	177575	144655	123750	105060	66975	54585	1500	293000	55
	29.3	151515	139050	117450	99900	61620	50050	1500	250000	55
	36.0	120000	103270	92180	91270	61360	49840	1500	198000	55
1353	62.0	177575	144655	123750	105060	66975	54585	1500	293000	35
	74.8	177575	144655	123750	105060	66975	54585	1500	293000	35
	84.9	151515	139050	117450	99900	61620	50050	1500	250000	35
	89.0	177575	144655	123750	105060	66975	54585	1500	293000	35
	107.3	177575	144655	123750	105060	66975	54585	1500	293000	35
	114.5	177575	144655	123750	105060	66975	54585	1500	293000	35
	125.6	151515	139050	117450	99900	61620	50050	1500	250000	35
	133.9	151515	139050	117450	99900	61620	50050	1500	250000	35
	140.5	177575	144655	123750	105060	66975	54585	1500	293000	35
	161.4	151515	139050	117450	99900	61620	50050	1500	250000	35
	169.3	177575	144655	123750	105060	66975	54585	1500	293000	35
198.1	151515	139050	117450	99900	61620	50050	1500	250000	35	
243.0	120000	103270	92180	91270	61360	49840	1500	198000	35	
1354	284.9	177575	144655	123750	105060	66975	54585	1800	293000	18
	320.0	151515	139050	117450	99900	61620	50050	1800	250000	18
	390.1	177575	144655	123750	105060	66975	54585	1800	293000	18
	404.7	177575	144655	123750	105060	66975	54585	1800	293000	18
	438.1	151515	139050	117450	99900	61620	50050	1800	250000	18
	473.4	151515	139050	117450	99900	61620	50050	1800	250000	18
	529.5	151515	139050	117450	99900	61620	50050	1800	250000	18
	608.5	151515	139050	117450	99900	61620	50050	1800	250000	18
	690.8	177575	144655	123750	105060	66975	54585	1800	293000	18
	746.7	151515	139050	117450	99900	61620	50050	1800	250000	18
	803.5	151515	139050	117450	99900	61620	50050	1800	250000	18
	862.7	120000	103270	92180	91270	61360	49840	1800	198000	18
	910.5	151515	139050	117450	99900	61620	50050	1800	250000	18
	968.4	151515	139050	117450	99900	61620	50050	1800	250000	18
	1018.4	177575	144655	123750	105060	66975	54585	1800	293000	18
	1040.0	120000	103270	92180	91270	61360	49840	1800	198000	18
	1188.4	151515	139050	117450	99900	61620	50050	1800	250000	18
	1253.9	120000	103270	92180	91270	61360	49840	1800	198000	18
1331.2	151515	139050	117450	99900	61620	50050	1800	250000	18	
1435.4	151515	139050	117450	99900	61620	50050	1800	250000	18	
1761.8	120000	103270	92180	91270	61360	49840	1800	198000	18	

PXA 1350

PXA 135

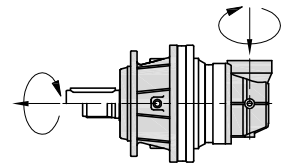

i	T ₂ (Nm)						n _{1max} (min ⁻¹)	T _{2max} (Nm)	P _t (kW)
	n ₂ x h								
	10000	25000	50000	100000	500000	1000000			

1353	61.9	177575	144655	123750	105060	66975	54585	1500	293000	35
	72.4	177575	144655	123750	105060	66975	54585	1500	293000	35
	75.7	177575	144655	123750	105060	66975	54585	1500	293000	35
	84.6	151515	139050	117450	99900	61620	50050	1500	250000	35
	88.3	177575	144655	123750	105060	66975	54585	1500	293000	35
	103.5	151515	139050	117450	99900	61620	50050	1500	250000	35
	108.7	177575	144655	123750	105060	66975	54585	1500	293000	35
	126.9	151515	139050	117450	99900	61620	50050	1500	250000	35
	155.9	120000	103270	92180	91270	61360	49840	1500	198000	35

1354	265.2	177575	144655	123750	105060	66975	54585	1800	293000	18
	309.5	177575	144655	123750	105060	66975	54585	1800	293000	18
	363.0	151515	139050	117450	99900	61620	50050	1800	250000	18
	380.5	177575	144655	123750	105060	66975	54585	1800	293000	18
	458.7	177575	144655	123750	105060	66975	54585	1800	293000	18
	489.5	177575	144655	123750	105060	66975	54585	1800	293000	18
	537.0	151515	139050	117450	99900	61620	50050	1800	250000	18
	572.4	151515	139050	117450	99900	61620	50050	1800	250000	18
	600.6	177575	144655	123750	105060	66975	54585	1800	293000	18
	690.0	151515	139050	117450	99900	61620	50050	1800	250000	18
	723.8	177575	144655	123750	105060	66975	54585	1800	293000	18
	846.9	151515	139050	117450	99900	61620	50050	1800	250000	18
	1038.8	120000	103270	92180	91270	61360	49840	1800	198000	18

PX / PXA 1350

FMS

FMC

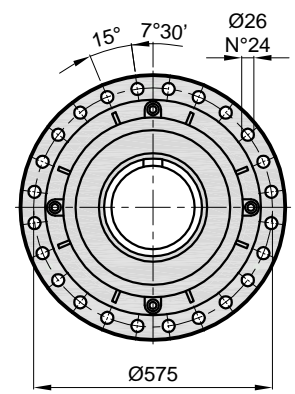
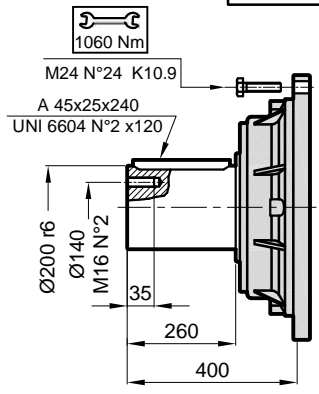
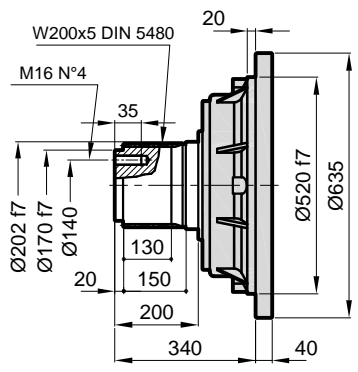

256

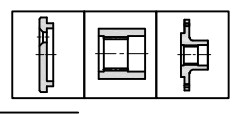

PX

PXA

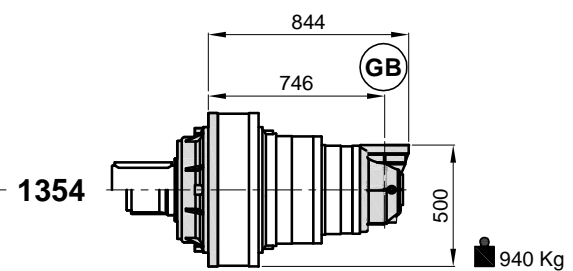
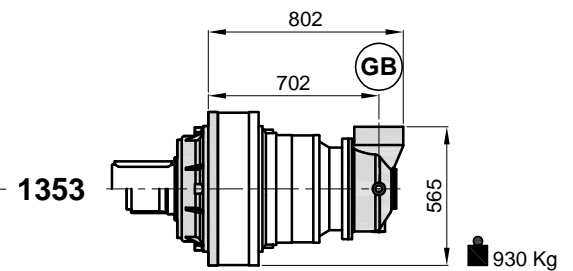
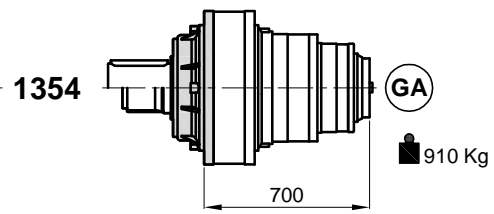
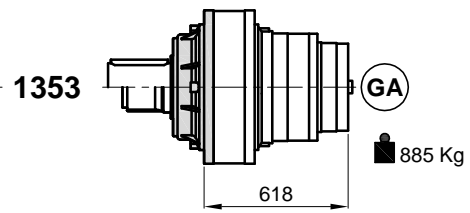
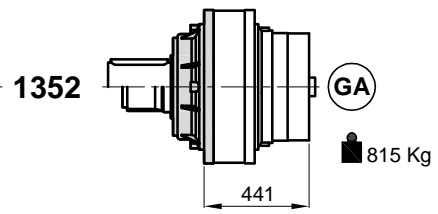
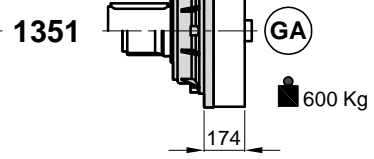

PX / PXA 1350

FSS

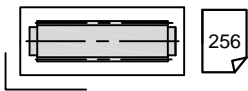
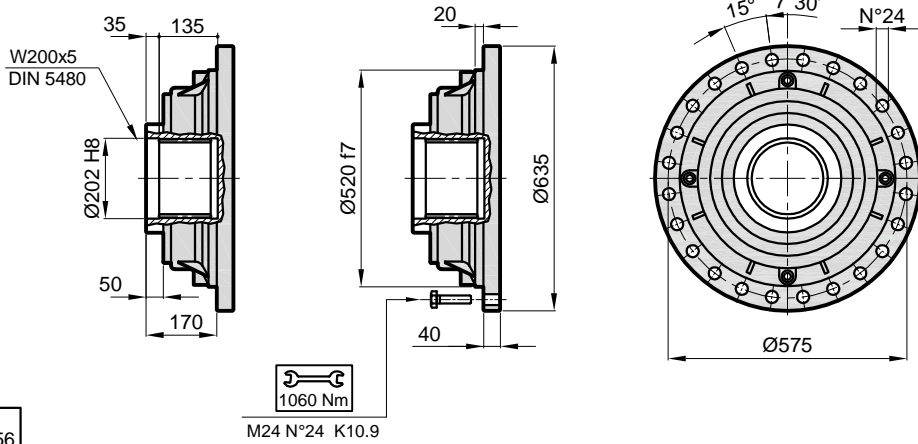

PX

PXA

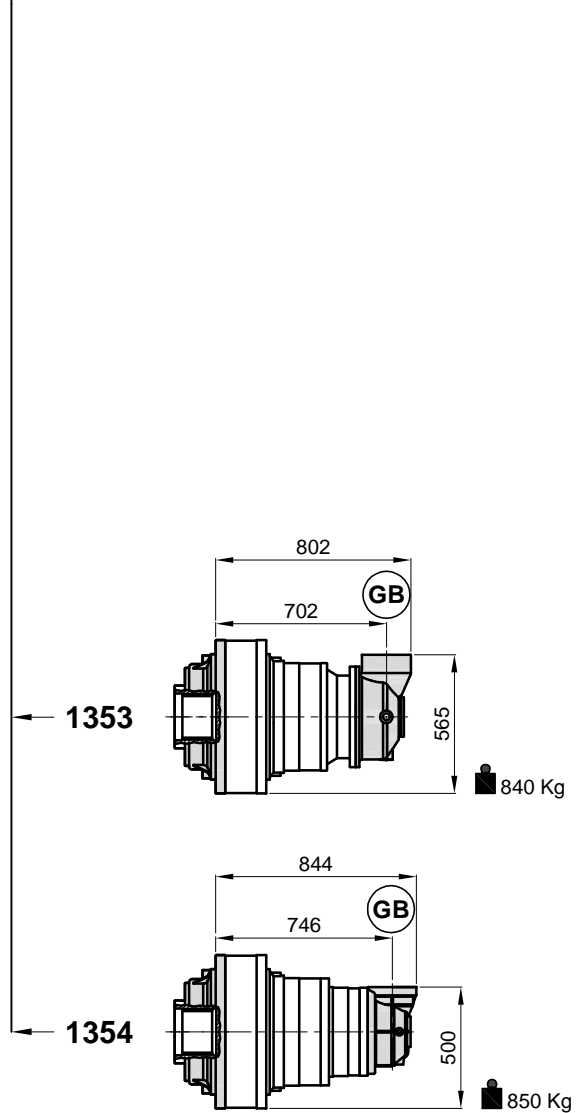
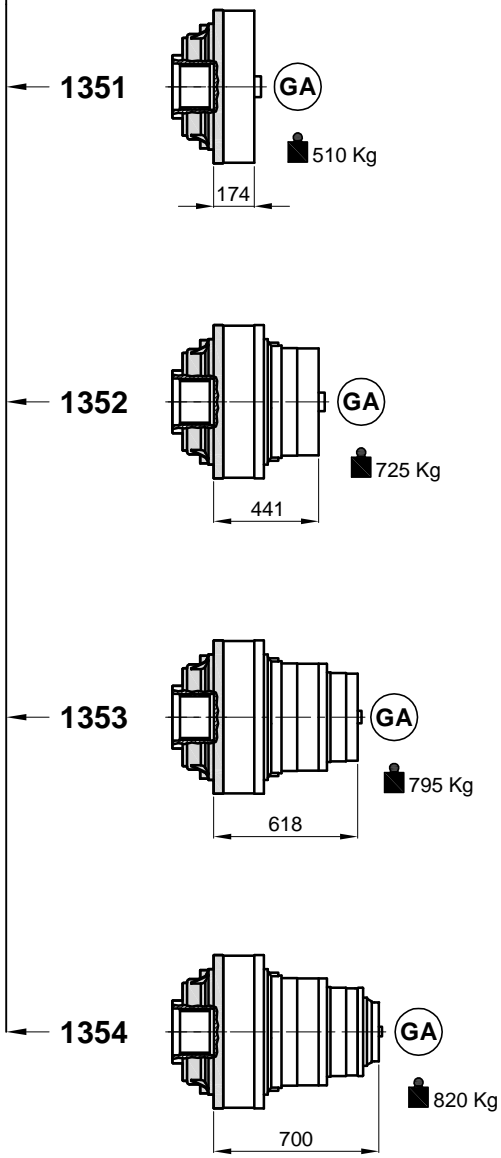

PX / PXA 1350

FSD

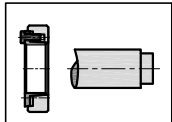
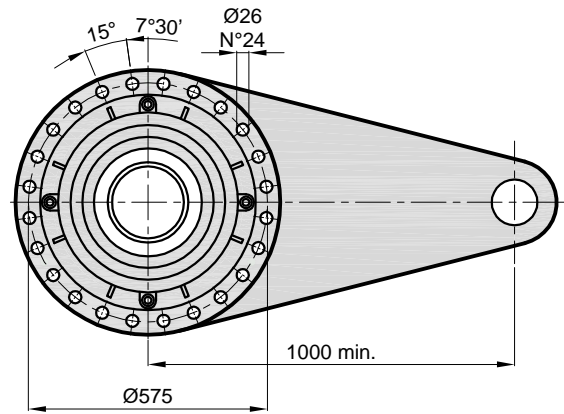
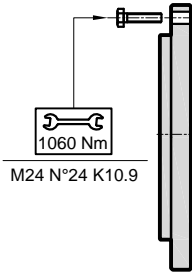
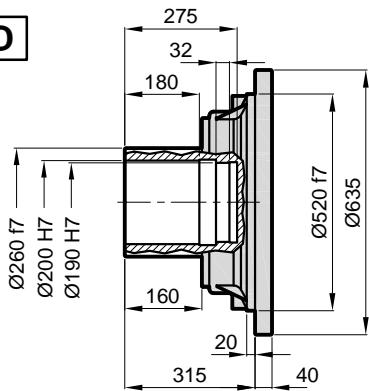

256

$M_{max} = 260 \text{ kNm}$

Maksimum tork de eri Planex tarafından verilen sıkma bilezi i ile sa lanır.
The maximum torque indicated is valid only with shrink discs supplied by Planex.
Das dargestellte , maximale Drehmoment gilt nur mit von Planex.

PX

1351

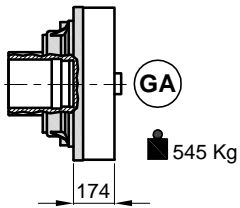

1352

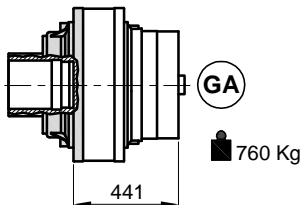

1353

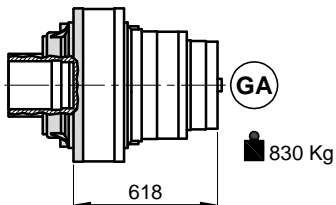

1354

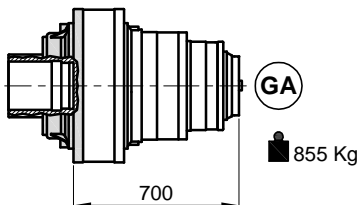

PXA

1353

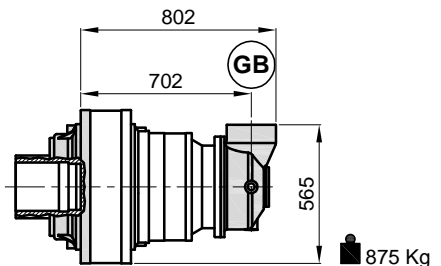

1354

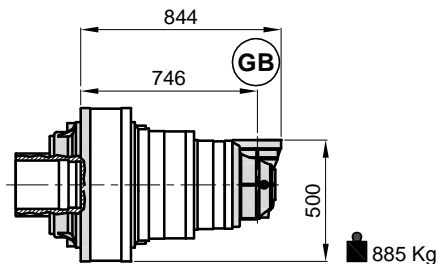

PX / PXA 1350

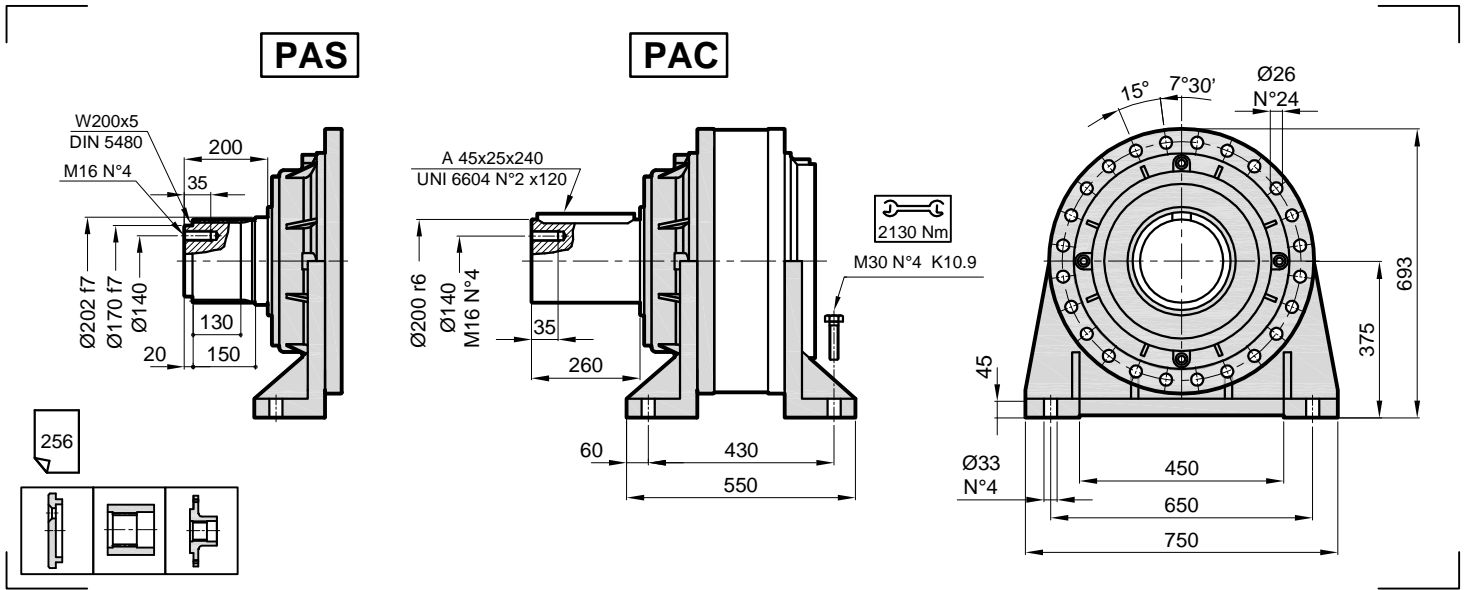

PX

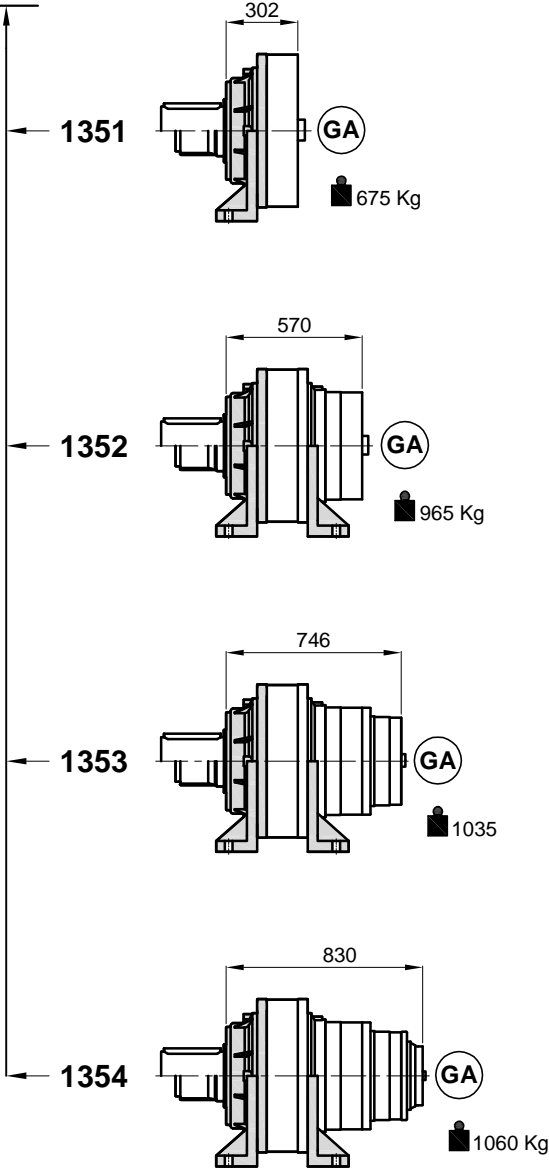

PXA

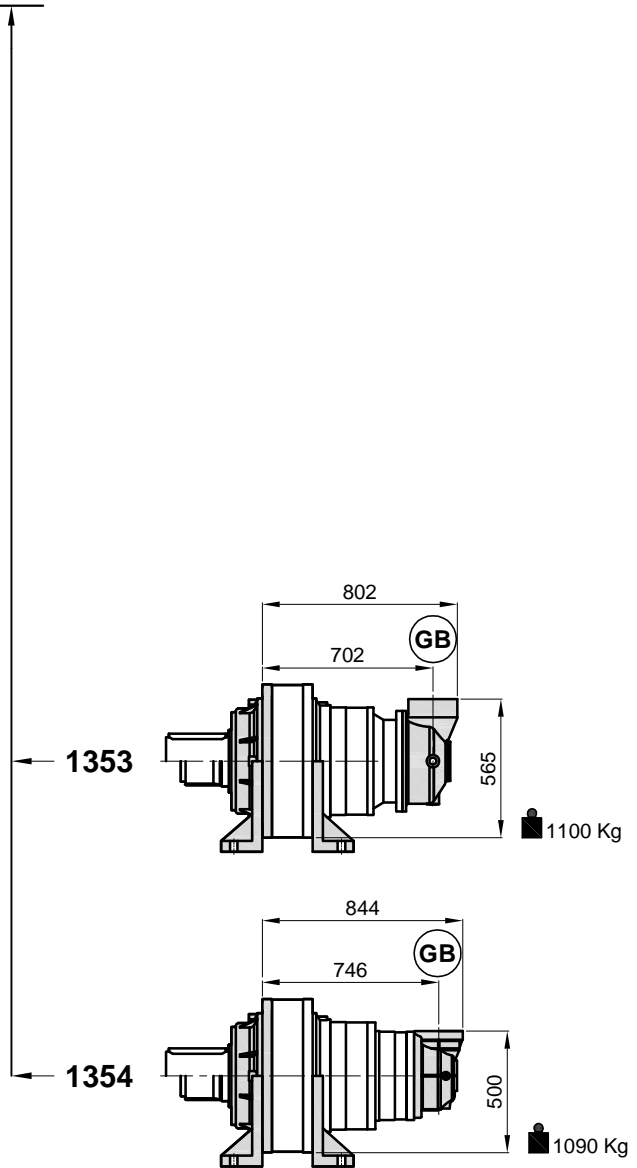

PX / PXA 1350

ET

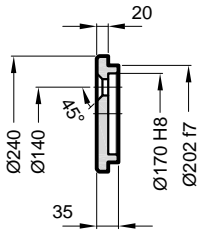

MC

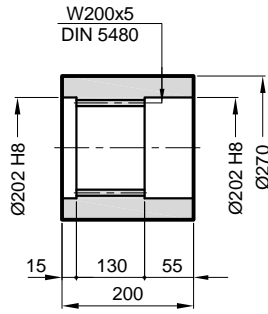

TF

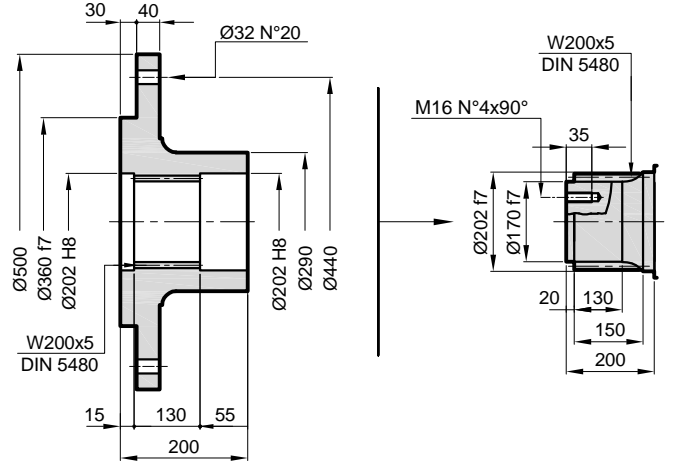

Malzeme / Material / Material
C40

Kod / Code / Bestell
1350.100.001

Malzeme / Material / Material
C40

Kod / Code / Bestell
1350.100.002

Malzeme / Material / Material
C40

Kod / Code / Bestell
1350.100.003

SD

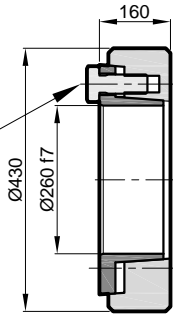
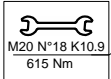

Maksimum tork
Max. torque
Max. Drehmoment
260 kNm

Kod / Code / Bestell
1350.100.004

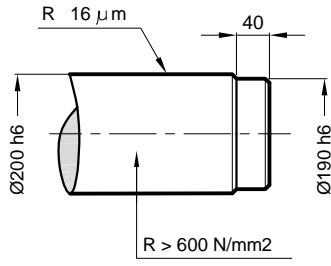

R > 600 N/mm2

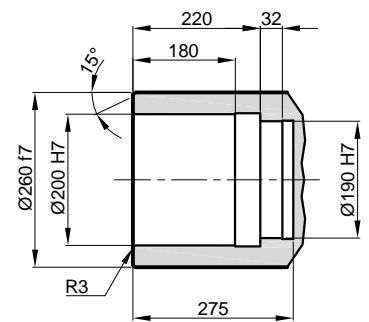

SM

W200x5
DIN 5480

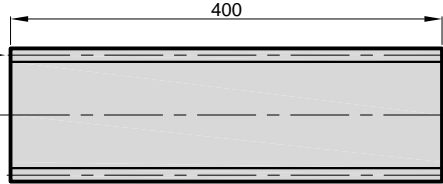

Malzeme / Material / Material

UNI 39NiCrMo3
Sertle tirilmi ve Temperlenmi
Hardened and Tempered
Vergütet

Kod / Code / Bestell
1350.100.005

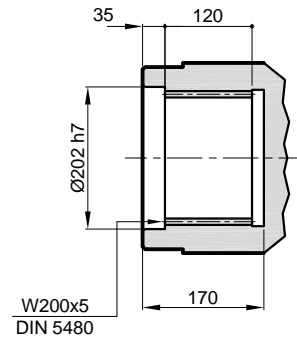

PX / PXA 1350

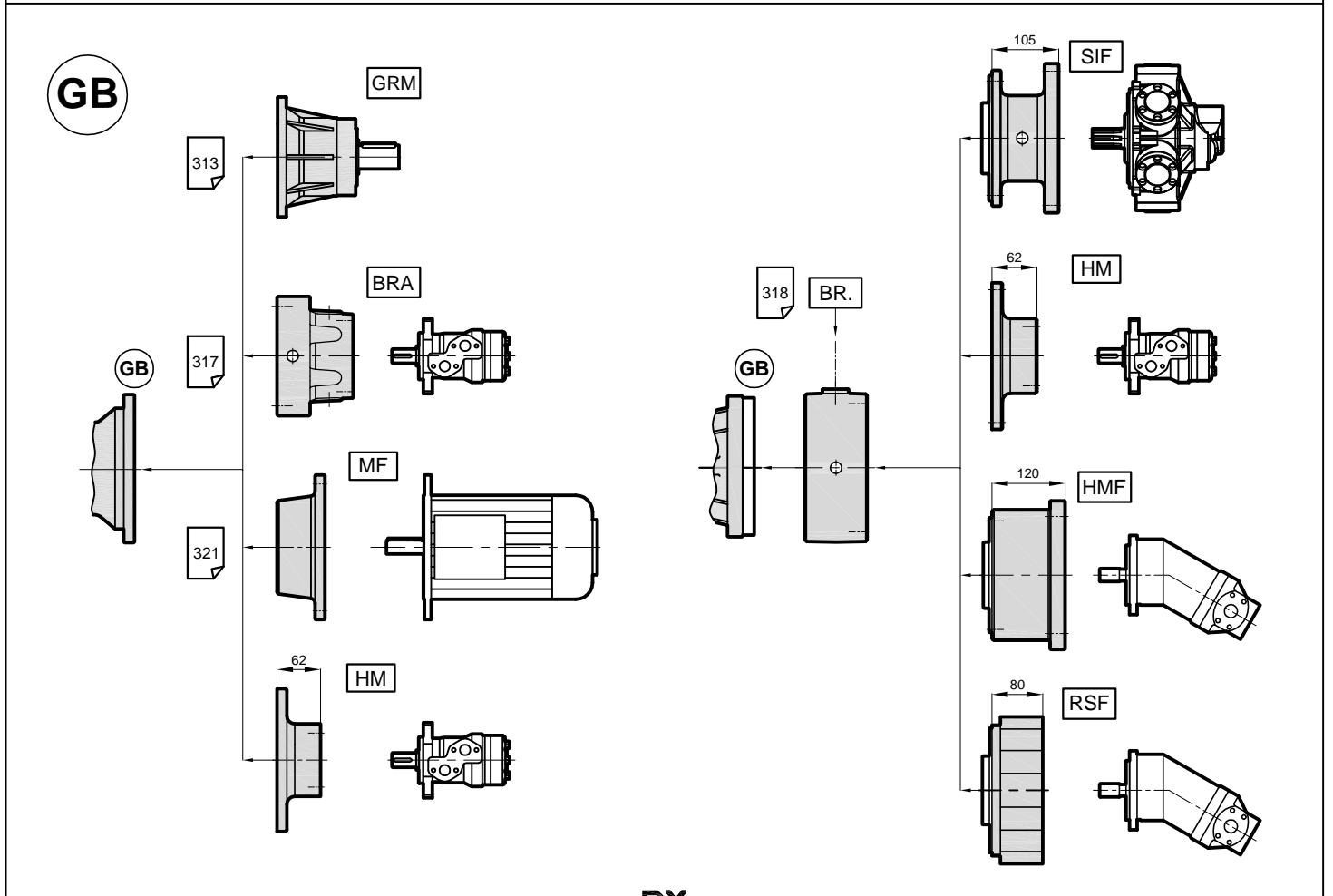
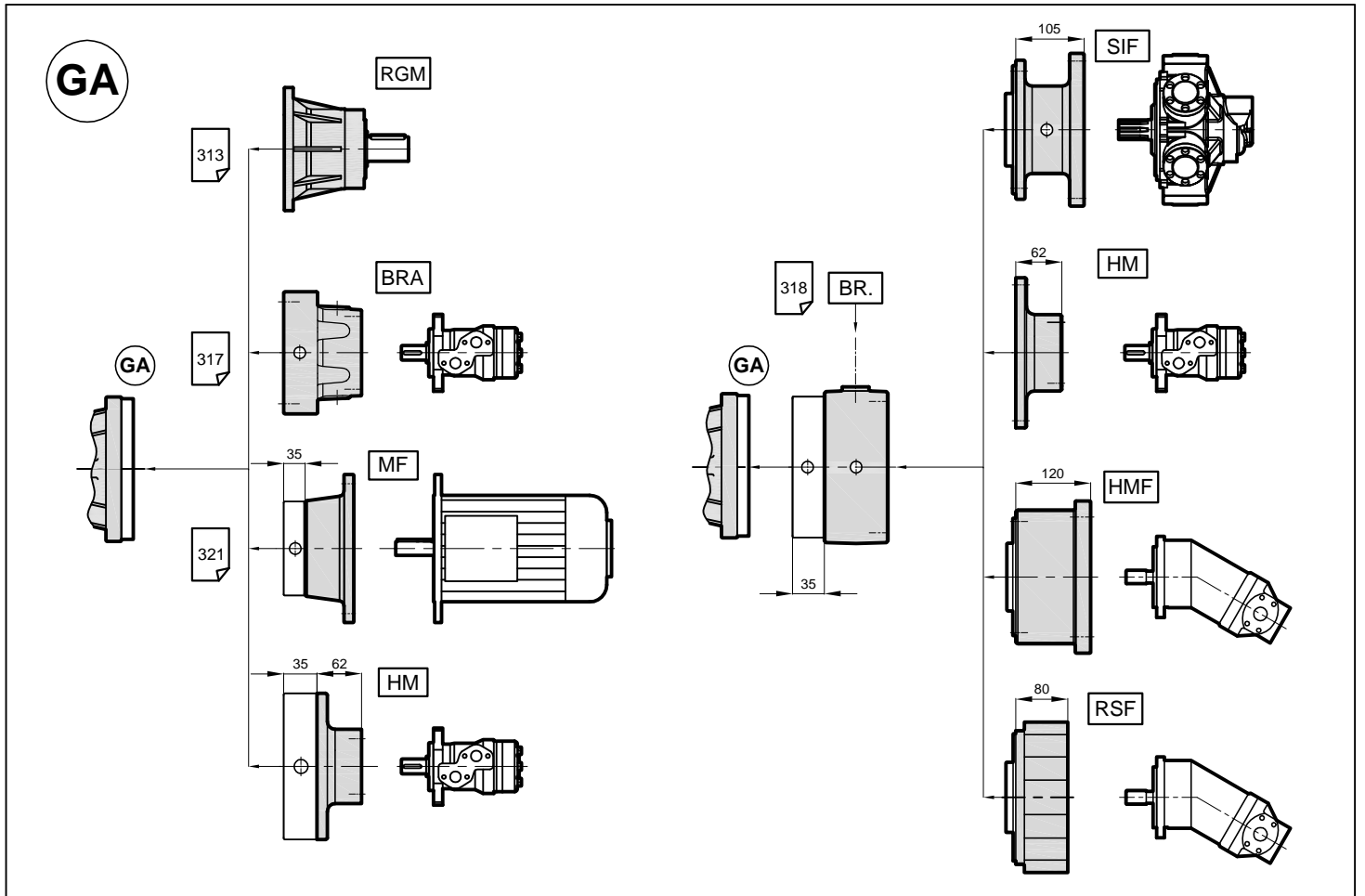

PX / PXA 1350

Radyal Yük (F_{rp})

Aşağıdaki diyagramlar radyal yükleri ve **K** faktörlerini arzu edilen $n_2 \times h$ değerlerinde verir.

Radial Loads (F_{rp})

The following curves show the radial loads and the **K** factors to obtain the required $n_2 \times h$ value.

Radiallast (F_{rp})

In den nachstehenden Diagrammen ist die Radiallast und der Koeffizient **K** dargestellt und kann mit dem gewünschten Wert $n_2 \times h$ verglichen werden.

FM - PA

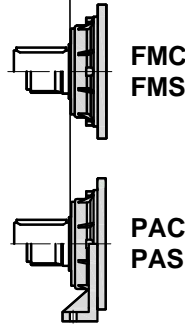
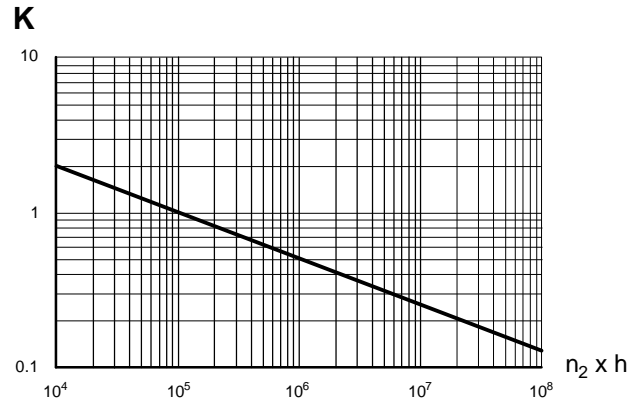
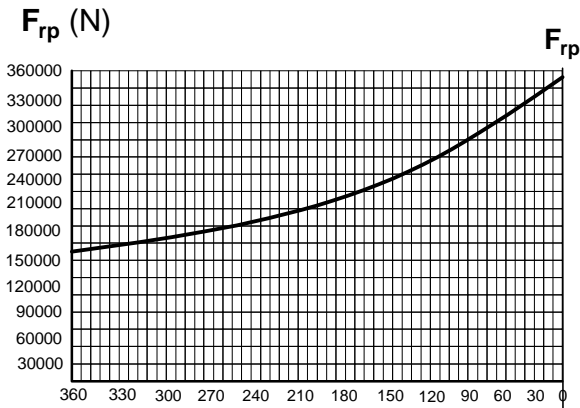

	$n_2 \times h$				
	10^5	10^4	10^6	10^7	10^8
FM	F_{rp}	$F_{rp} \cdot K$			
PA	$F_{rp} \cdot 0,75$	$F_{rp} \cdot K \cdot 0,75$			

Aksiyel Yük (F_a)

Tablodaki aksiyel yük değerleri çıkış tipi ve tatbik edilen yük yönünde verilmiştir.

Axial Loads (F_a)

The values of the axial loads in the table refer to the output versions and load directions of application.

Axiellast (F_a)

Die dargestellten Werte der Axiallast basieren auf der Version und der applizierten Lastrichtung.

F_a (N)	FM	PA	← →
		45000 75000	

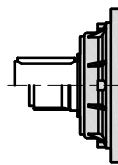

FMC
FMS

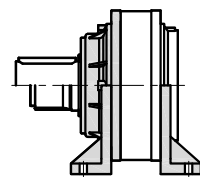

PAC
PAS