

PX 1410

PX 141

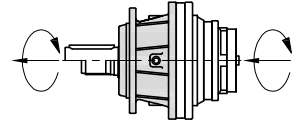

i	T ₂ (Nm)						n _{1max} (min ⁻¹)	T _{2max} (Nm)	P _t (kW)	
	n ₂ x h									
	10000	25000	50000	100000	500000	1000000				
1411	4.18	490900	395680	317190	258000	159192	129300	200	810000	115
	4.89	420600	340200	272710	224990	140500	112750	200	694000	115
	6.00	334000	288540	258300	222400	137230	111460	200	551000	115
1412	17.4	490900	395680	317190	258000	159192	129300	500	810000	70
	20.4	490900	395680	317190	258000	159192	129300	500	810000	70
	23.9	420600	340200	272710	224990	140500	112750	500	694000	70
	25.1	490900	395680	317190	258000	159192	129300	500	810000	70
	29.3	420600	340200	272710	224990	140500	112750	500	694000	70
	36.0	334000	288540	258300	222400	137230	111460	500	551000	70
1413	73.0	490900	395680	317190	258000	159192	129300	1500	810000	50
	85.3	490900	395680	317190	258000	159192	129300	1500	810000	50
	99.8	490900	395680	317190	258000	159192	129300	1500	810000	50
	105.0	490900	395680	317190	258000	159192	129300	1500	810000	50
	116.9	420600	340200	272710	224990	140500	112750	1500	694000	50
	122.4	490900	395680	317190	258000	159192	129300	1500	810000	50
	127.3	490900	395680	317190	258000	159192	129300	1500	810000	50
	143.3	420600	340200	272710	224990	140500	112750	1500	694000	50
	150.6	420600	340200	272710	224990	140500	112750	1500	694000	50
	177.6	420600	340200	272710	224990	140500	112750	1500	694000	50
216.0	334000	288540	258300	222400	137230	111460	1500	551000	50	
1414	259.3	490900	395680	317190	258000	159192	129300	1500	810000	30
	302.8	490900	395680	317190	258000	159192	129300	1500	810000	30
	354.3	490900	395680	317190	258000	159192	129300	1500	810000	30
	427.1	490900	395680	317190	258000	159192	129300	1500	810000	30
	497.8	420600	340200	272710	224990	140500	112750	1500	694000	30
	544.8	490900	395680	317190	258000	159192	129300	1500	810000	30
	685.4	490900	395680	317190	258000	159192	129300	1500	810000	30
	789.1	420600	340200	272710	224990	140500	112750	1500	694000	30
	843.4	420600	340200	272710	224990	140500	112750	1500	694000	30
	967.3	420600	340200	272710	224990	140500	112750	1500	694000	30
	1061.2	490900	395680	317190	258000	159192	129300	1500	810000	30
	1193.8	420600	340200	272710	224990	140500	112750	1500	694000	30
	1242.4	420600	340200	272710	224990	140500	112750	1500	694000	30
	1305.7	420600	340200	272710	224990	140500	112750	1500	694000	30
	1458.0	334000	288540	258300	222400	137230	111460	1500	551000	30
1872.7	334000	288540	258300	222400	137230	111460	1500	551000	30	

PXA 1410

PXA 141

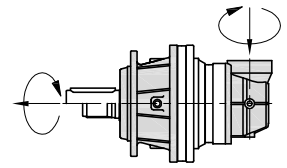

i	T ₂ (Nm)						n _{1max} (min ⁻¹)	T _{2max} (Nm)	P _t (kW)
	n ₂ x h								
	10000	25000	50000	100000	500000	1000000			

1414	258.4	490900	395680	317190	258000	159192	129300	1500	810000	30
	302.0	490900	395680	317190	258000	159192	129300	1500	810000	30
	353.3	490900	395680	317190	258000	159192	129300	1500	810000	30
	361.1	490900	395680	317190	258000	159192	129300	1500	810000	30
	369.3	490900	395680	317190	258000	159192	129300	1500	810000	30
	413.8	420600	340200	272710	224990	140500	112750	1500	694000	30
	433.3	490900	395680	317190	258000	159192	129300	1500	810000	30
	454.7	490900	395680	317190	258000	159192	129300	1500	810000	30
	507.3	420600	340200	272710	224990	140500	112750	1500	694000	30
	530.3	490900	395680	317190	258000	159192	129300	1500	810000	30
	551.2	490900	395680	317190	258000	159192	129300	1500	810000	30
	620.5	420600	340200	272710	224990	140500	112750	1500	694000	30
	652.1	420600	340200	272710	224990	140500	112750	1500	694000	30
	769.0	420600	340200	272710	224990	140500	112750	1500	694000	30
935.3	334000	288540	258300	222400	137230	111460	1500	551000	30	

PX / PXA 1410

FMS

FMC

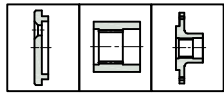
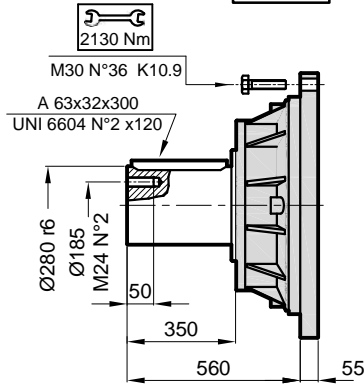
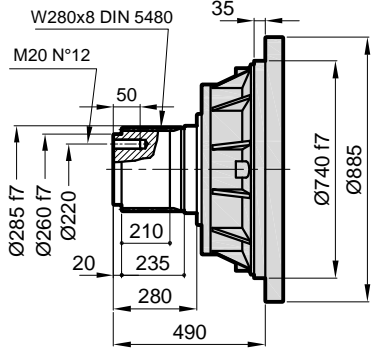

PX

PXA

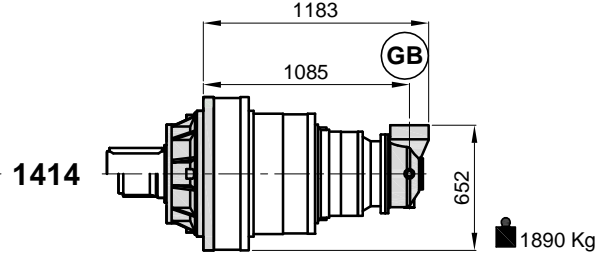
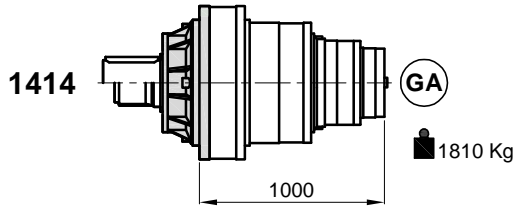
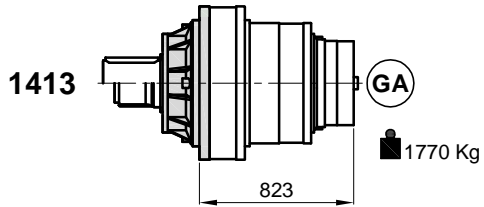
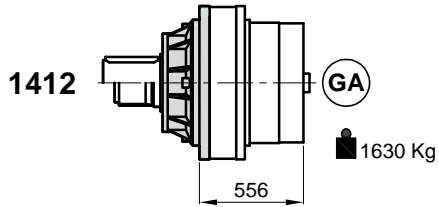
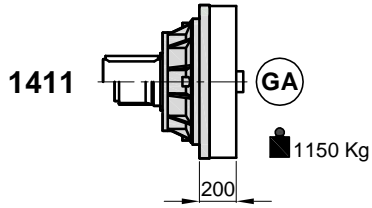

PX / PXA 1410

FSS

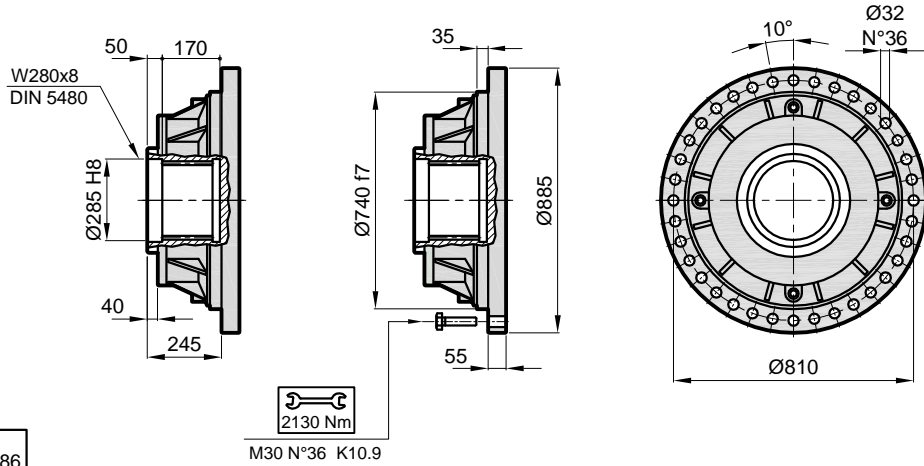

PX

PXA

1411

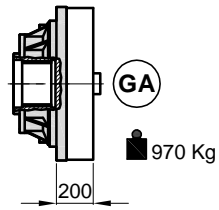

1412

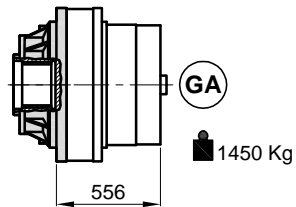

1413

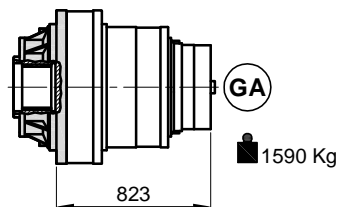

1414

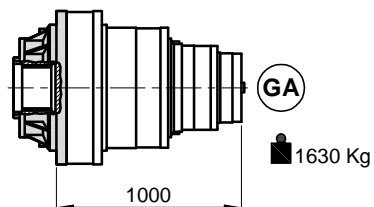

1414

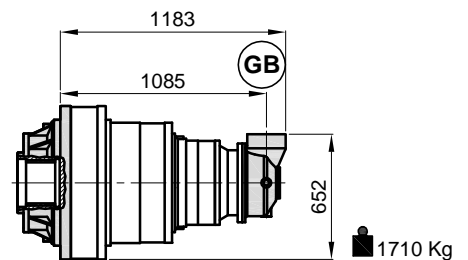

PX / PXA 1410

FSD

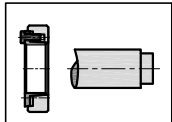
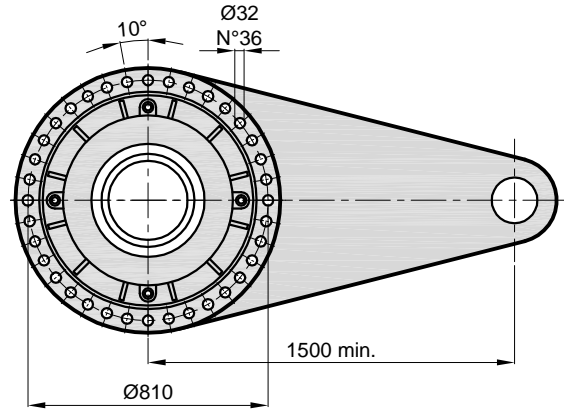
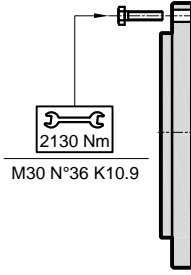
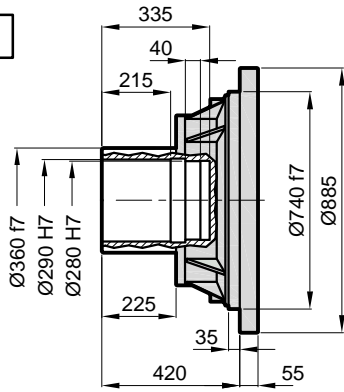

286

$M_{max} = 803 \text{ kNm}$

Maksimum tork de eri Planex tarafından verilen sıkma bilezi i ile sa lanır.
The maximum torque indicated is valid only with shrink discs supplied by Planex.
Das dargestellte , maximale Drehmoment gilt nur mit von Planex.

PX

PXA

1411

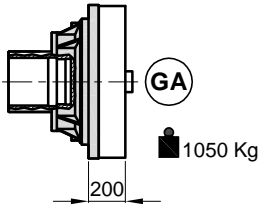

1412

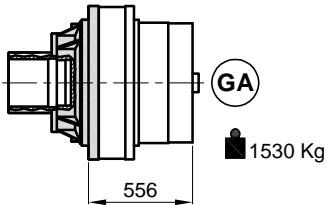

1413

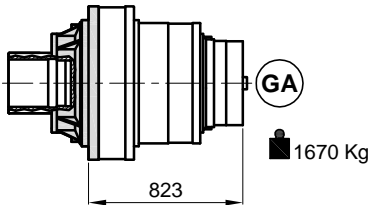

1414

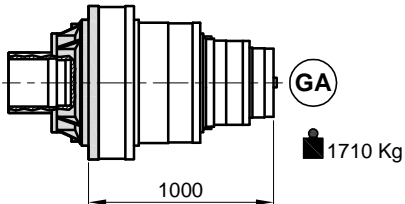

1414

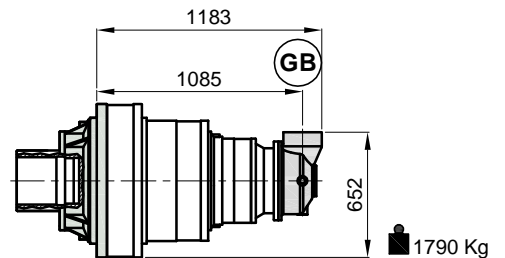

PX / PXA 1410

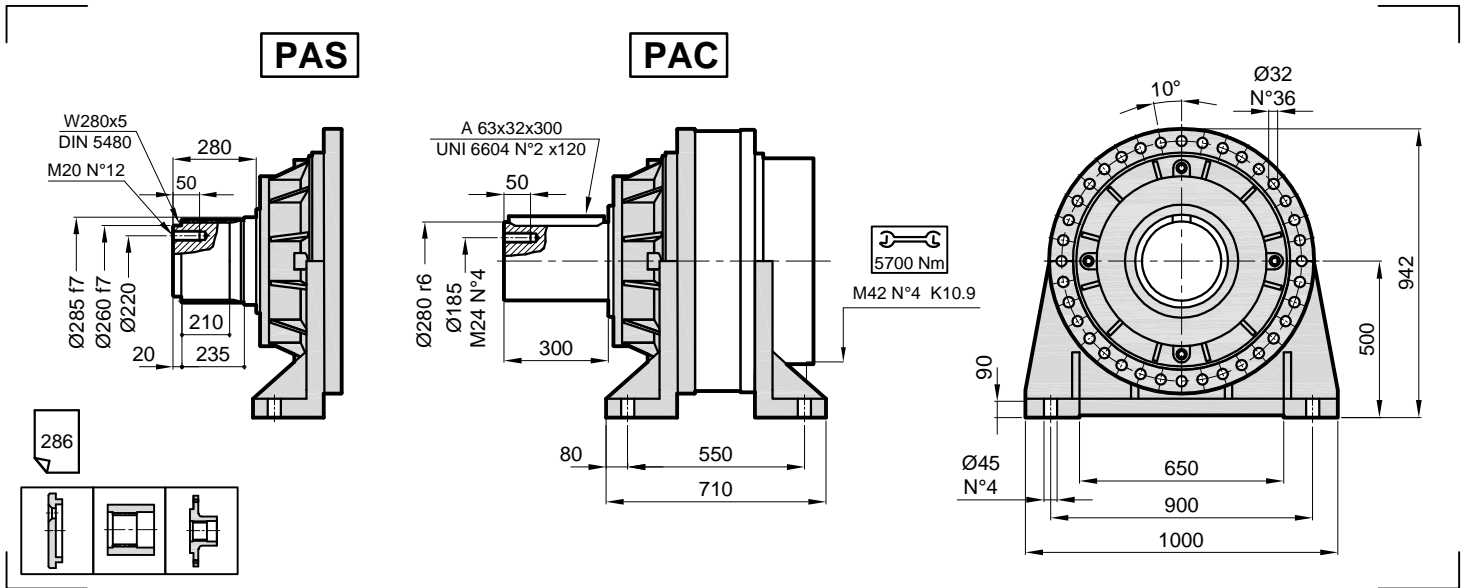

PX

1411

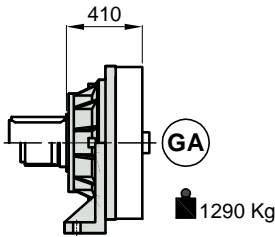

1412

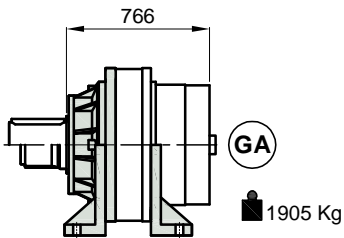

1413

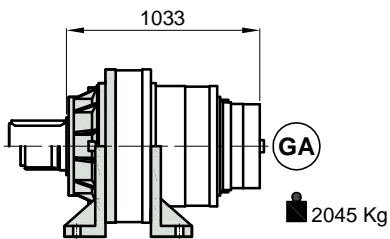

1414

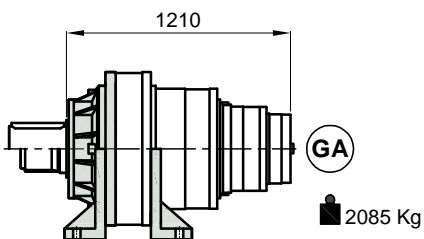

PXA

1414

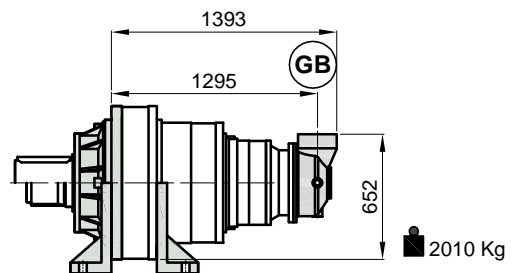

PX / PXA 1410

ET

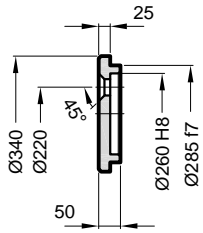

MC

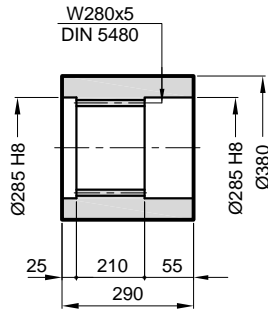

TF

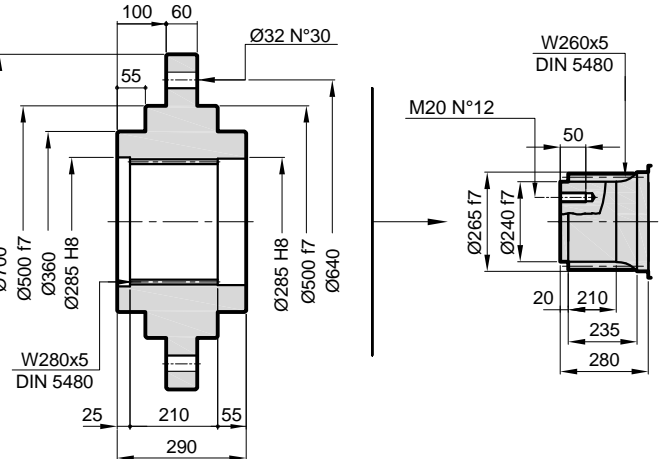

Malzeme / Material / Material
C40

Kod / Code / Bestell
1410.100.001

Malzeme / Material / Material
C40

Kod / Code / Bestell
1410.100.002

Malzeme / Material / Material
C40

Kod / Code / Bestell
1410.100.003

SD

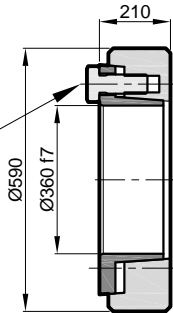
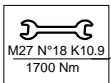

Maksimum tork
Max. torque
Max. Drehmoment
803 kNm

Kod / Code / Bestell
1410.100.004

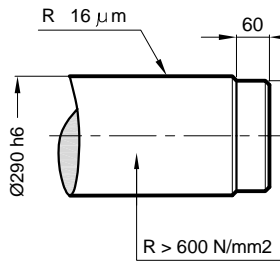

R > 600 N/mm²

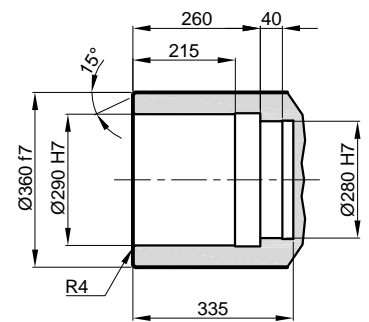

SM

W280x5
DIN 5480

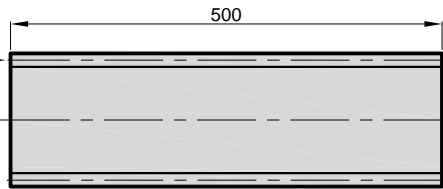

Malzeme / Material / Material

UNI 39NiCrMo3
Sertleştirilmiş ve Temperlenmiş
Hardened and Tempered
Vergütet

Kod / Code / Bestell
1410.100.005

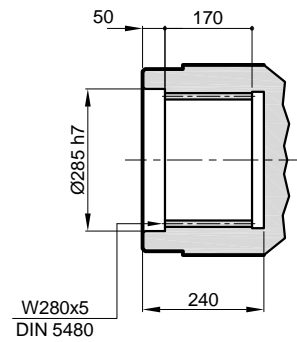

W280x5
DIN 5480

PX / PXA 1410

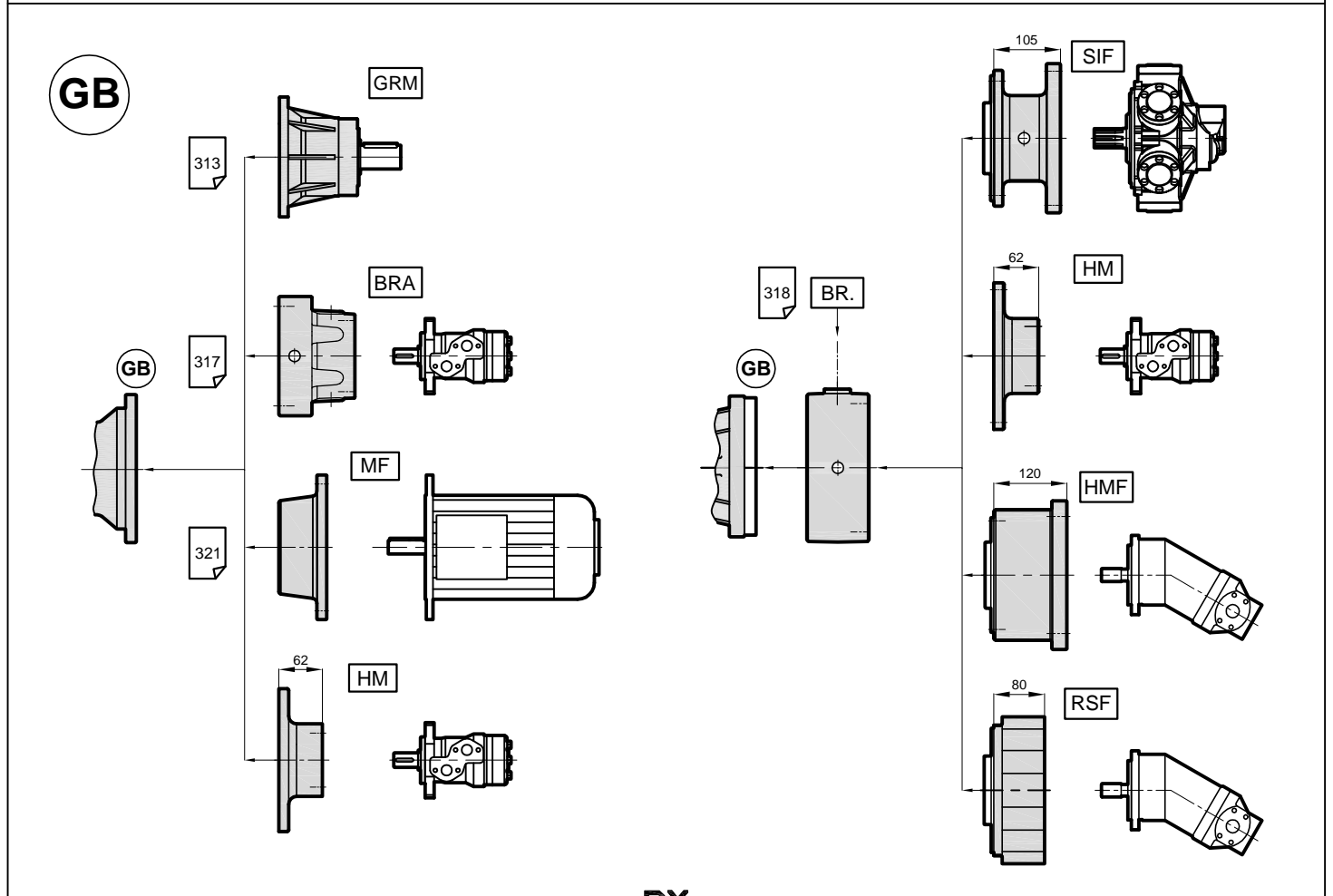
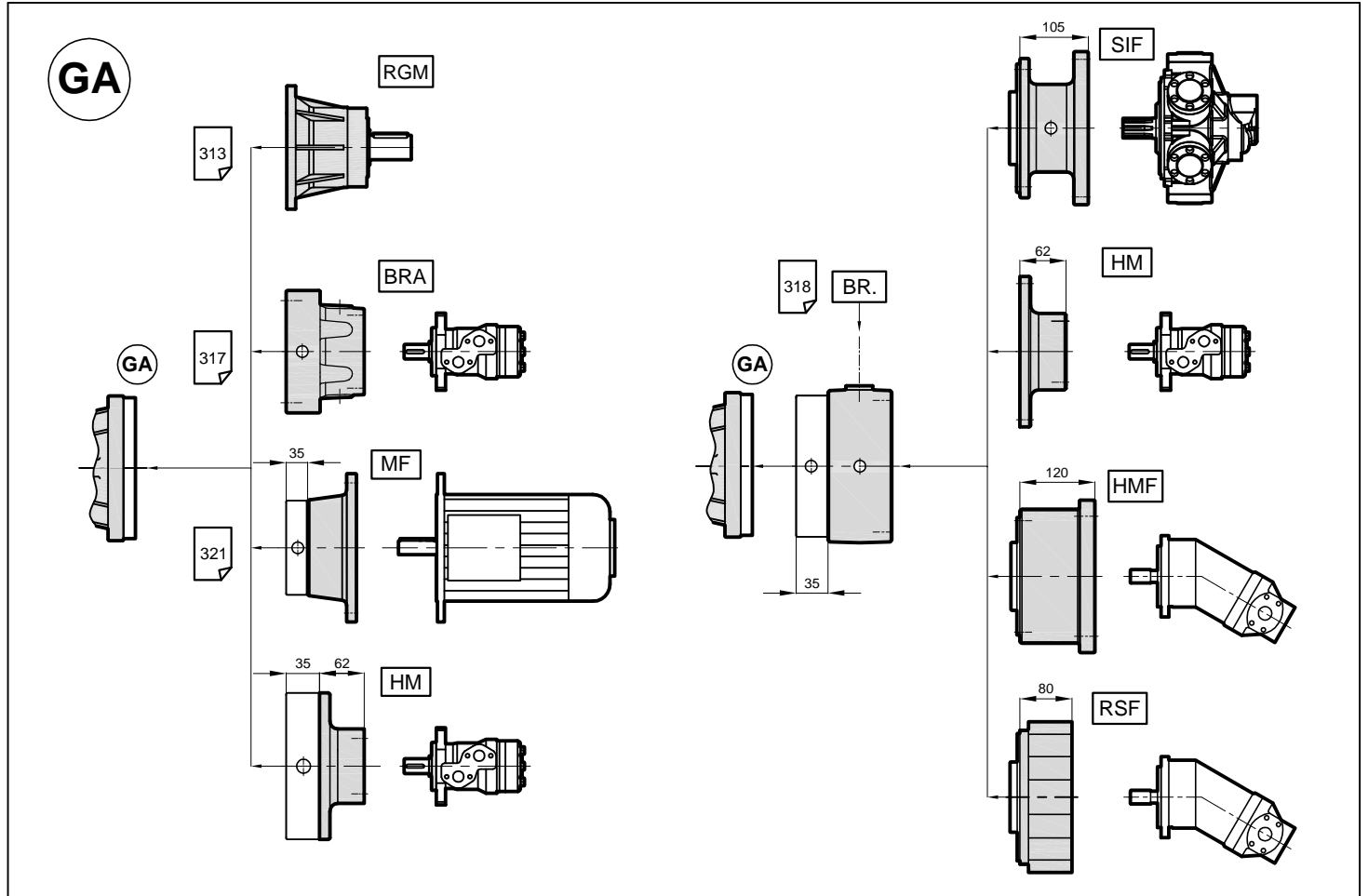

PX / PXA 1410

Radyal Yük (F_{rp})

Aşağıdaki diyagramlar radyal yükleri ve K faktörlerini arzu edilen $n_2 \times h$ değerlerinde verir.

Radial Loads (F_{rp})

The following curves show the radial loads and the K factors to obtain the required $n_2 \times h$ value.

Radiallast (F_{rp})

In den nachstehenden Diagrammen ist die Radiallast und der Koeffizient K dargestellt und kann mit dem gewünschten Wert $n_2 \times h$ verglichen werden.

FM - PA

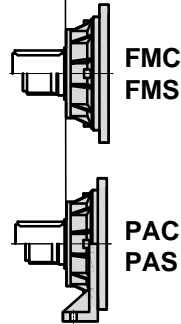
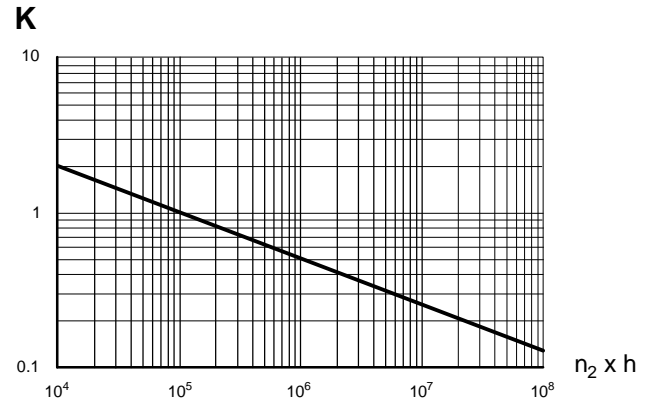
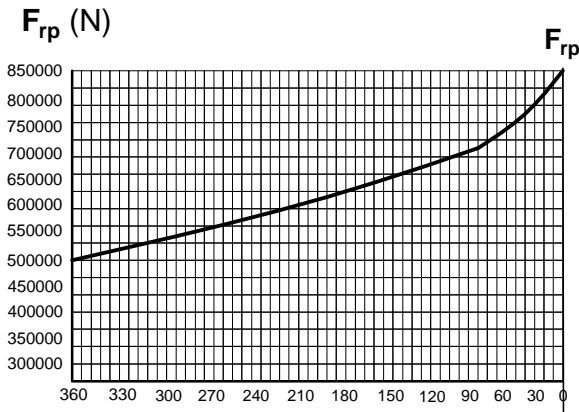

	$n_2 \times h$				
	10^5	10^4	10^6	10^7	10^8
FM	F_{rp}	$F_{rp} \cdot K$			
PA	$F_{rp} \cdot 0,75$	$F_{rp} \cdot K \cdot 0,75$			

Aksiyel Yük (F_a)



Tablodaki aksiyel yük değerleri çıkış tipi ve tatbik edilen yük yönünde verilmiştir.

Axial Loads (F_a)

The values of the axial loads in the table refer to the output versions and load directions of application.

Axiellast (F_a)

Die dargestellten Werte der Axiallast basieren auf der Version und der applizierten Lastrichtung.

F_a (N)	FM	PA	
	100000	100000	
120000	120000	120000	

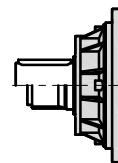

FMC
FMS

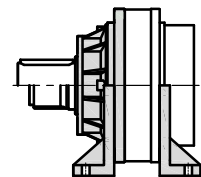

PAC
PAS