

Mobil Vinç Grubu
Bu bölümde orta moment olarak
niteleyebileceğimiz
T = 3400 - 200000 Nm redüktör
tipleri PX 1132 - PXV 350
bulunmaktadır.



T = 68.8 - 195 KNm

PX 1250 - 1330

$T_{2max} = 3400 - 200000 \text{ Nm}$

		
PX - PXA 1250	T = 35250 - 66800 Nm	172
PX - PXA 1270	T = 49500 - 77500 Nm	188
PX - PXA 1290	T = 58750 - 98000 Nm	204
PX - PXA 1310	T = 87840 - 140000 Nm	220
PX - PXA 1330	T = 118180 - 195000 Nm	234

Mobil

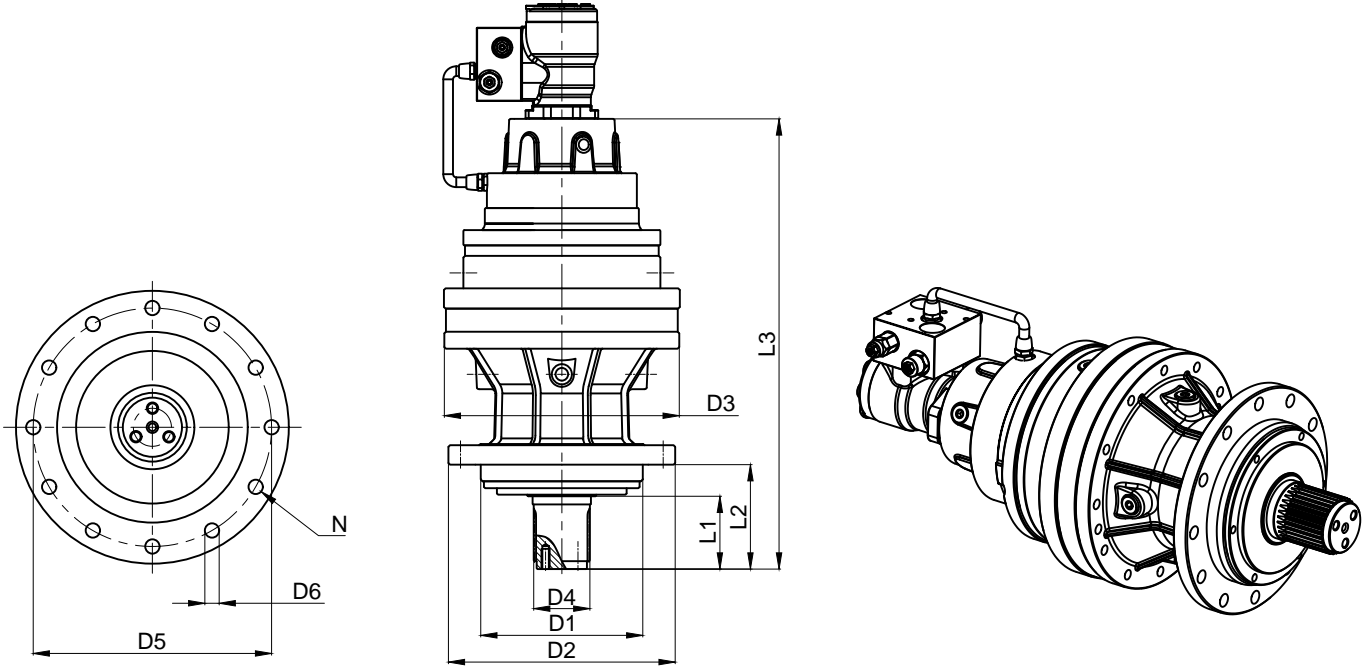

Tip	D1	D2	D3	D4	D5	D6	N	L1	L2	L3
PX 1132	110	185	185	40x36	165	10,5	8	55	62	347
PX 1152	175	272	245	58x53	245	13	10	80	120	430
PX 1172	175	272	245	58x53	245	13	10	80	120	455
PX 1192	200	280	290	70x64	250	16	12	90	131	557
PX 1212	230	325	360	80x74	295	17	10	90	126	538
PX 1232	230	325	410	80x74	295	17	10	90	126	557

Tip	Tahvil	Fren	Güç/HP	Max Moment
PX 1132	28,9	BRA120	MP100	3400 Nm
PX 1152	28,9	BRA130	MP125	5320 Nm
PX 1172	28,9	BRA140	MP200	7850 Nm
PX 1192	30	BRA140	MP250	12000 Nm
PX 1212	40,5	BRA150	MP315	13700 Nm
PX 1232	40,5	BRA150	MP315	18800 Nm

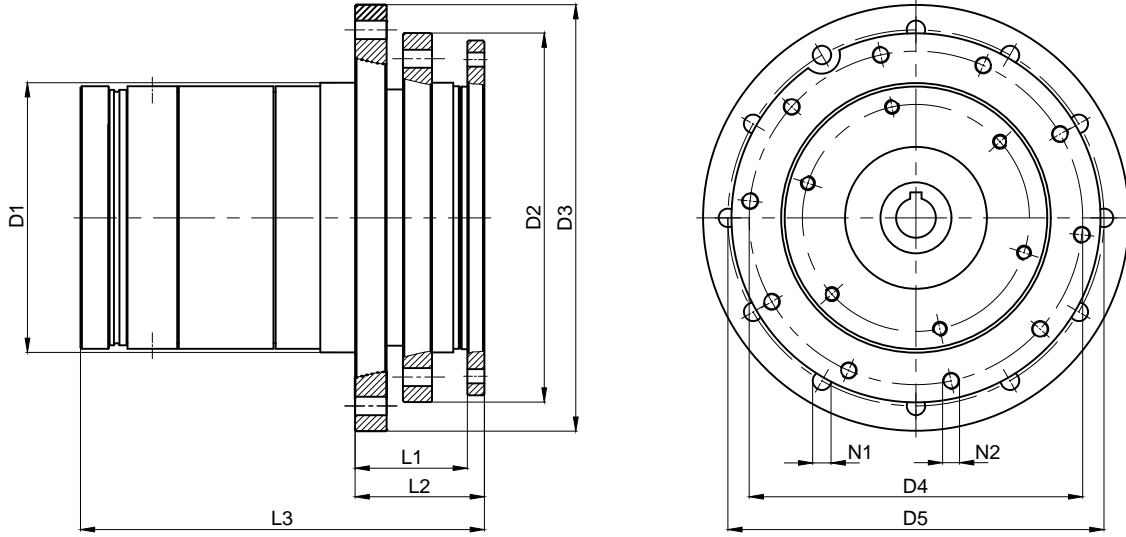

Tip	D1	D2	D3	D4	D5	N1	N2	L1	L2	L3
PXV 130	190	260	300	235	265	13	M12	80	90	285
PXV 170	270	300	360	270	325	15	M14	98	128	377
PXV 190	280	335	370	300	330	17	M16	85	115	315
PXV 210	360	395	460	310	428	21	M20	60	90	385
PXV 250	410	430	485	390	455	21	M20	130	160	480
PXV 310	500	450	640	320	640	21	M20	95	245	762
PXV 350	630	550	740	550	680	24	M24	95	285	840

Tip	Tahvil Oranı	T ₂	T _{2max}
PXV 130	44,8 - 53,9 - 68 - 85 - 111,3	2350 Nm	4500 Nm
PXV 170	53,5 - 70,5 - 85,2 - 102,7 - 115,5	7650 Nm	13750 Nm
PXV 190	61 - 80,5 - 114	11500 Nm	22500 Nm
PXV 210	53,9 - 70,5 - 85 - 102,5 - 134,1	24250 Nm	48500 Nm
PXV 250	73,7 - 89 - 100,7 - 116,8 - 141	35000 Nm	62000 Nm
PXV 310	56,2 - 73,1 - 99,7 - 115,6 - 139	100000 Nm	138500 Nm
PXV 350	71,6 - 93,1 - 117,8 - 133 - 185,5	138500 Nm	200000 Nm